

BioVendor

Research
and Diagnostic Products

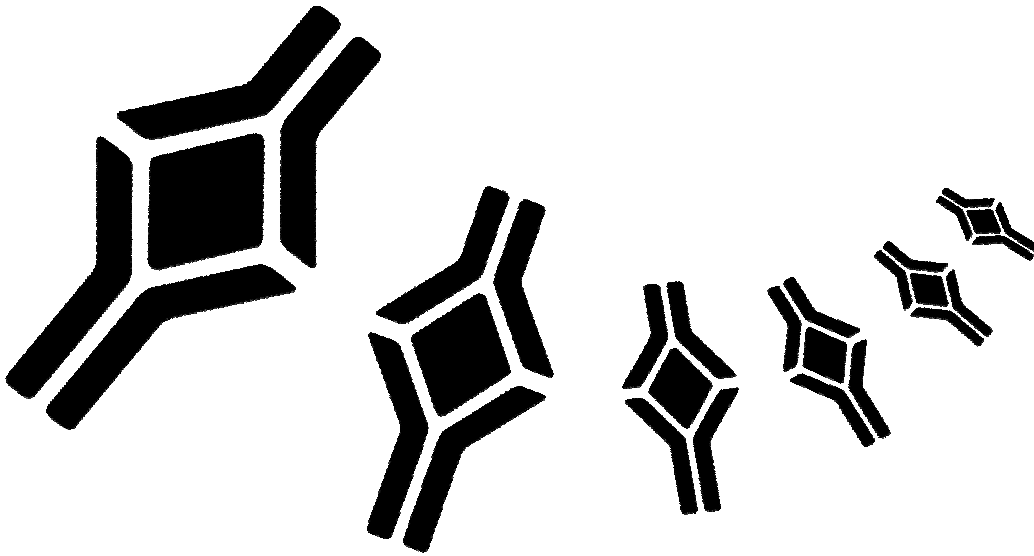

MONKEY sTNF-R I ELISA

Product Data Sheet

Cat. No.: RBMS653R

For Research Use Only

CONTENTS

1.	INTENDED USE	3
2.	SUMMARY	3
3.	PRINCIPLES OF THE TEST	4
4.	REAGENTS PROVIDED	6
5.	STORAGE INSTRUCTIONS	7
6.	SPECIMEN COLLECTION	7
7.	MATERIALS REQUIRED BUT NOT PROVIDED	8
8.	PRECAUTIONS FOR USE	9
9.	PREPARATION OF REAGENTS	11
10.	TEST PROTOCOL	15
11.	CALCULATION OF RESULTS	19
12.	LIMITATIONS	22
13.	PERFORMANCE CHARACTERISTICS	23
14.	REFERENCES	25
15.	REAGENT PREPARATION SUMMARY	27
16.	TEST PROTOCOL SUMMARY	28

**»» This kit is manufactured by:
BioVendor – Laboratorní medicína, a.s.**

»» Use only the current version of Product Data Sheet enclosed with the kit!

1 INTENDED USE

The monkey sTNF-R I ELISA is an enzyme-linked immunosorbent assay for quantitative detection of soluble monkey Tumor Necrosis Factor-Receptor I levels in cell culture supernatants, monkey serum, plasma or other body fluids. **The monkey sTNF-R I ELISA is for research use only. Not for use in diagnostic or therapeutic procedures.**

2 SUMMARY

Tumor Necrosis Factor (TNF) was originally discovered in sera of animals and was found to cause hemorrhagic necrosis of some transplantable mouse and human tumors and to exhibit primarily cytotoxic activities against tumor but not normal cells in vitro (7,11). The TNF family consists of two proteins designated TNF- α , also called cachectin (5), and TNF- β , also called lymphotoxin (12), which are pleiotropic cytokines that can mediate a wide variety of biological effects (2).

Both TNF- α and TNF- β have been shown to interact with a cell through specific high affinity receptors with a few hundred up to more than 20,000 copies per cell (3,8,9,10,13,14,15,17). TNF-receptors have been demonstrated on a wide variety of somatic cells including fibroblasts (9), endothelial cells, adipocytes, liver membranes (4), granulocytes and several tumor cell lines (1,6,8,16).

3 PRINCIPLES OF THE TEST

An anti-monkey-sTNF-R I monoclonal coating antibody is adsorbed onto microwells.

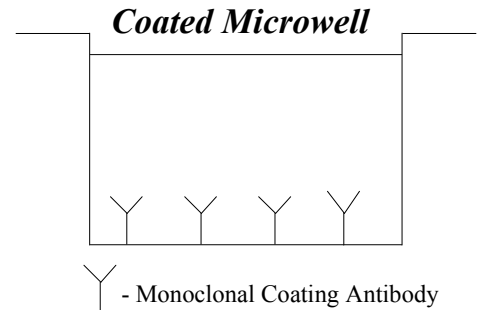

Monkey sTNF-R I present in the sample or standard binds to antibodies adsorbed to the microwells; a HRP-conjugated monoclonal anti-monkey-sTNF-R I antibody is added and binds to monkey sTNF-R I captured by the first antibody.

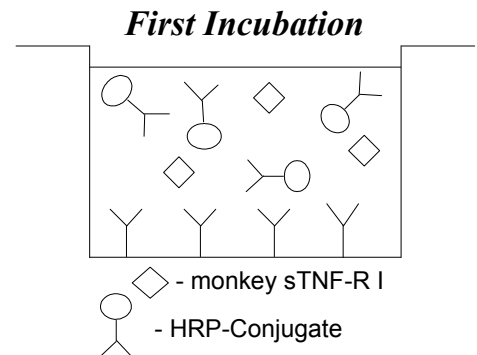

Following incubation unbound enzyme conjugated anti-monkey-sTNF-R I is removed during a wash step and substrate solution reactive with HRP is added to the wells.

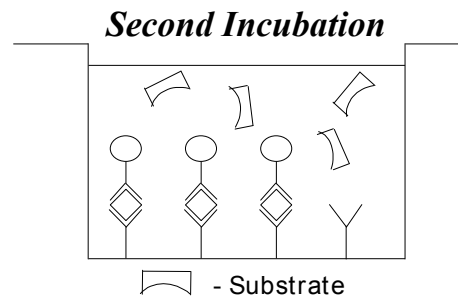

A coloured product is formed in proportion to the amount of soluble monkey TNF-R I present in the sample. The reaction is terminated by addition of acid and absorbance is measured at 450nm. A standard curve is prepared from seven monkey sTNF-R I standard dilutions and monkey sTNF-R I sample concentration determined.

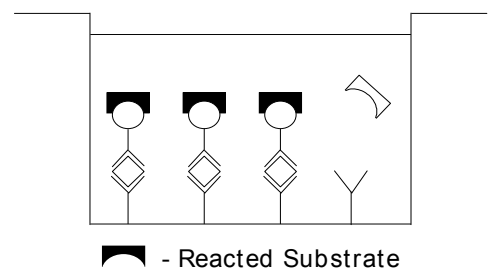

4 REAGENTS PROVIDED

- 1 aluminium pouch with a **Antibody Coated Microtiter Strips with Monoclonal Antibody** (murine) to monkey sTNF-R I
- 1 vial (0.2 ml) **HRP-Conjugate** anti-monkey-sTNF-R I monoclonal (murine) antibody
- 2 vials (0.05 ml) **monkey sTNF-R I Standard** concentrate
- 1 bottle (50 ml) **Wash Buffer Concentrate** 20x (PBS with 1% Tween 20)
- 1 vial (5 ml) **Assay Buffer Concentrate** 20x (PBS with 1% Tween 20 and 10% BSA)
- 1 vial (15 ml) **Substrate Solution**
- 1 vial (12 ml) **Stop Solution** (1M Phosphoric acid)
- 2 vials (0.4 ml each) **Blue-Dye, Green-Dye**
- 2 adhesive **Plate Covers**

Reagent Labels

5 STORAGE INSTRUCTIONS

Store kit reagents between 2° and 8°C. Immediately after use remaining reagents should be returned to cold storage (2° to 8°C). Expiry of the kit and reagents is stated on labels.

The expiry of the kit components can only be guaranteed if the components are stored properly, and if, in case of repeated use of one component, the reagent is not contaminated by the first handling.

6 SPECIMEN COLLECTION

Cell culture supernatants, monkey serum, plasma, or other biological samples will be suitable for use in the assay.

Samples containing a visible precipitate must be clarified prior to use in the assay. Do not use grossly hemolyzed or lipemic specimens.

Clinical samples should be kept at 2° to 8°C and separated rapidly before storing at -20°C to avoid loss of bioactive monkey sTNF-R I. If samples are to be run within 24 hours, they may be stored at 2° to 8°C. Avoid repeated freeze-thaw cycles.

For stability of samples refer to 13. E.

7 MATERIALS REQUIRED BUT NOT PROVIDED

- 5 ml and 10 ml graduated pipettes
- 10 μ l to 1,000 μ l adjustable single channel micropipettes with disposable tips
- 50 μ l to 300 μ l adjustable multichannel micropipette with disposable tips
- Multichannel micropipette reservoir
- Beakers, flasks, cylinders necessary for preparation of reagents
- Device for delivery of wash solution (multichannel wash bottle or automatic wash system)
- Microwell strip reader capable of reading at 450 nm (620 nm as optional reference wave length)
- Glass-distilled or deionized water
- Statistical calculator with program to perform linear regression analysis

8 PRECAUTIONS FOR USE

- All chemicals should be considered as potentially hazardous. We therefore recommend that this product is handled only by those persons who have been trained in laboratory techniques and that it is used in accordance with the principles of good laboratory practice. Wear suitable protective clothing such as laboratory overalls, safety glasses and gloves. Care should be taken to avoid contact with skin or eyes. In the case of contact with skin or eyes wash immediately with water. See material safety data sheet(s) and/or safety statements(s) for specific advice.
- Reagents are intended for research use only and are not for use in diagnostic or therapeutic procedures.
- Do not mix or substitute reagents with those from other lots or other sources.
- Do not use kit reagents beyond expiration date on label.
- Do not expose kit reagents to strong light during storage or incubation.
- Do not pipette by mouth.
- Do not eat or smoke in areas where kit reagents or samples are handled.
- Avoid contact of skin or mucous membranes with kit reagents or specimens.
- Rubber or disposable latex gloves should be worn while handling kit reagents or specimens.
- Avoid contact of substrate solution with oxidizing agents and metal.
- Avoid splashing or generation of aerosols.

- In order to avoid microbial contamination or cross-contamination of reagents or specimens which may invalidate the test use disposable pipette tips and/or pipettes.
- Use clean, dedicated reagent trays for dispensing the conjugate and substrate reagents.
- Exposure to acids will inactivate the conjugate.
- Glass-distilled water or deionized water must be used for reagent preparation.
- Substrate solution must be at room temperature prior to use.
- Decontaminate and dispose specimens and all potentially contaminated materials as if they could contain infectious agents. The preferred method of decontamination is autoclaving for a minimum of 1 hour at 121.5°C.
- Liquid wastes not containing acid and neutralized waste may be mixed with sodium hypochlorite in volumes such that the final mixture contains 1.0% sodium hypochlorite. Allow 30 minutes for effective decontamination. Liquid waste containing acid must be neutralized prior to the addition of sodium hypochlorite.

9 PREPARATION OF REAGENTS

Except for the HRP-Conjugate (reagent C.) and the monkey sTNF-R I Standard (reagent D.) the reagents should be prepared before starting with the test procedure.

A. Wash Buffer

If crystals have formed in the Wash Buffer Concentrate, warm it gently until they have completely dissolved.

Pour entire contents (50 ml) of the **Wash Buffer Concentrate** into a clean 1,000 ml graduated cylinder. Bring final volume to 1,000 ml with glass-distilled or deionized water. Mix gently to avoid foaming. The pH of the final solution should adjust to 7.4.

Transfer to a clean wash bottle and store at 2° to 25°C. Please note that the Wash Buffer is stable for 30 days. Wash Buffer may be prepared as needed according to the following table:

Number of Strips	Wash Buffer Concentrate (ml)	Distilled Water (ml)
1 - 6	25	475
1 - 12	50	950

B. Assay Buffer

Mix the contents of the bottle well. Add contents of **Assay Buffer Concentrate** (5.0 ml) to 95 ml distilled or deionized water and mix gently to avoid foaming. Store at 2° to 8°C. Please note that the Assay Buffer is stable for 30 days. Assay Buffer may be prepared as needed according to the following table:

Number of Strips	Assay Buffer Concentrate (ml)	Distilled Water (ml)
1 - 6	2.5	47.5
1 - 12	5.0	95.0

C. Preparation of HRP-Conjugate

The **HRP-Conjugate** must be diluted 1:100 with Assay Buffer (reagent B.) just prior to use in a clean plastic test tube.

Please note that the HRP-Conjugate should be used within 30 minutes after dilution. HRP-Conjugate may be prepared as needed according to the following table:

Number of Strips	HRP-Conjugate (ml)	Assay Buffer (ml)
1 - 6	0.03	2.97
1 - 12	0.06	5.94

D. Preparation of monkey sTNF-R I Standard

Add **Assay Buffer** as stated on the label of the standard vial to one vial of concentrated **monkey sTNF-R I Standard** as needed. Shake gently to mix. Store diluted Standard promptly at - 20°C after use. Discard after one week.

E. Addition of colour-giving reagents: Blue-Dye, Green-Dye

This procedure is optional, does not in any way interfere with the test results, and is designed to help the customer with the performance of the test, but can also be omitted, just following the instruction booklet. Alternatively, the dye solutions from the stocks provided (**Blue-Dye, Green-Dye**) can be added to the reagents according to the following guidelines:

1. Diluent: Before sample dilution add the **Blue-Dye** at a dilution of 1:250 (see table below) to the Assay Buffer according to the test protocol. After addition of **Blue-Dye**, proceed according to the instruction booklet.

5 ml Assay Buffer	20 µl Blue-Dye
12 ml Assay Buffer	48 µl Blue-Dye
50 ml Assay Buffer	200 µl Blue-Dye
60 ml Assay Buffer	240 µl Blue-Dye

2. HRP-Conjugate: Before dilution of the concentrated conjugate, add the **Green-Dye** at a dilution of 1:100 (see table below) to the Assay Buffer used for the final conjugate dilution. Proceed after addition of **Green-Dye** according to the instruction booklet, preparation of HRP-conjugate.

3 ml Assay Buffer	30 µl Green-Dye
6 ml Assay Buffer	60 µl Green-Dye
12 ml Assay Buffer	120 µl Green-Dye

10 TEST PROTOCOL

- a. Mix all reagents thoroughly without foaming before use.
- b. Determine the number of Microwell Strips required to test the desired number of samples plus appropriate number of wells needed for running blanks and standards. Each sample, standard, blank, and optional control sample should be assayed in duplicate. Remove extra **Microwell Strips coated with Monoclonal Antibody** (murine) to monkey sTNF-R I from holder and store in foil bag with the desiccant provided at 2°-8°C sealed tightly.
- c. Wash the microwell strips twice with approximately 300 µl **Wash Buffer** per well with thorough aspiration of microwell contents between washes. Take care not to scratch the surface of the microwells.

After the last wash, empty wells and tap microwell strips on absorbent pad or paper towel to remove excess Wash Buffer. Use the microwell strips immediately after washing or place upside down on a wet absorbent paper for not longer than 15 minutes. Do not allow wells to dry.

- d. Add 100 µl of **Assay Buffer** in duplicate to all standard wells. Prepare standard dilutions by pipetting 100 µl of diluted (Refer to preparation of reagents, 9.D.) **monkey sTNF-R Standard**, in duplicate, into well A1 and A2 (see Figure 1 and 2). Mix the contents by repeated aspiration and ejection, and transfer 100 µl to well B1 and B2, respectively. Take care not to scratch the inner surface of the microwells. Continue this procedure five times, creating two rows of monkey sTNF-R I standard dilutions ranging from 6 to 0.09 U/ml. Discard 100 µl of the contents from the last microwells (G1, G2) used.

Figure 1. Preparation of monkey sTNF-R I standard dilutions:

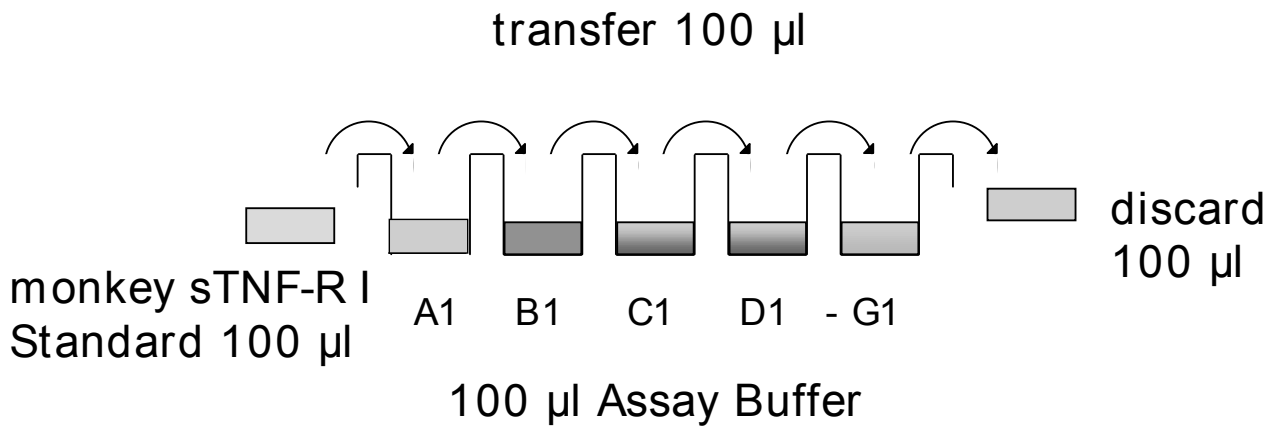

Figure 2. Diagram depicting an example of the arrangement of blanks, standards and samples in the microwell strips:

	1	2	3	4
A	Standard 1 (6 U/ml)	Standard 1 (6 U/ml)	Sample 1	Sample 1
B	Standard 2 (3 U/ml)	Standard 2 (3 U/ml)	Sample 2	Sample 2
C	Standard 3 (1.5 U/ml)	Standard 3 (1.5 U/ml)	Sample 3	Sample 3
D	Standard 4 (0.75 U/ml)	Standard 4 (0.75 U/ml)	Sample 4	Sample 4
E	Standard 5 (0.375 U/ml)	Standard 5 (0.375 U/ml)	Sample 5	Sample 5
F	Standard 6 (0.19 U/ml)	Standard 6 (0.19 U/ml)	Sample 6	Sample 6
G	Standard 7 (0.09 U/ml)	Standard 7 (0.09 U/ml)	Sample 7	Sample 7
H	Blank	Blank	Sample 8	Sample 8

- e. Add 100 µl of **Assay Buffer** in duplicate to the blank wells.
- f. Add 90 µl of **Assay Buffer** to all wells designated for samples.
- g. Add 10 µl of each **Sample**, in duplicate, to the designated wells and mix the contents.
- h. Prepare **HRP-Conjugate**. (Refer to preparation of reagents 9.C.)
- i. Add 50 µl of diluted (1:100) **HRP-Conjugate** to all wells, including the blank wells.
- j. Cover with a **Plate Cover** and incubate at room temperature (18° to 25°C) for 2 hours, if available on a rotator set at 100 rpm.
- k. Remove Plate Cover and empty wells. Wash microwell strips 3 times according to point c. of the test protocol. Proceed immediately to the next step.
- l. Pipette 100 µl of **TMB Substrate Solution** to all wells, including the blank wells.
- m. Incubate the microwell strips at room temperature (18° to 25°C) for about 10 minutes. Avoid direct exposure to intense light.
The colour development on the plate should be monitored and the substrate reaction stopped (see point n. of this protocol) before positive wells are no longer properly recordable.
It is recommended to add the stop solution when the highest standard has developed a dark blue colour.
Alternatively the colour development can be monitored by the ELISA reader at 620 nm. The substrate reaction should be stopped as soon as an OD of 0.6 – 0.65 is reached.

- n. Stop the enzyme reaction by quickly pipetting 100 μ l of **Stop Solution** into each well, including the blank wells. It is important that the Stop Solution is spread quickly and uniformly throughout the microwells to completely inactivate the enzyme. Results must be read immediately after the Stop Solution is added or within one hour if the microwell strips are stored at 2 - 8°C in the dark.
- o. Read absorbance of each microwell on a spectro-photometer using 450 nm as the primary wave length (optionally 620 nm as the reference wave length; 610 nm to 650 nm is acceptable). Blank the plate reader according to the manufacturer's instructions by using the blank wells. Determine the absorbance of both, the samples and the monkey sTNF-R I standards.

Note: In case of incubation without shaking the obtained O.D. values may be lower than indicated below. Nevertheless the results are still valid.

11 CALCULATION OF RESULTS

- Calculate the average absorbance values for each set of duplicate standards and samples. Duplicates should be within 20 per cent of the mean.
- Create a standard curve by plotting the mean absorbance for each standard concentration on the ordinate against the monkey sTNF-R I concentration on the abscissa. Draw a best fit curve through the points of the graph.
- To determine the concentration of circulating monkey sTNF-R I for each sample, first find the mean absorbance value on the ordinate and extend a horizontal line to the standard curve. At the point of intersection, extend a vertical line to the abscissa and read the corresponding monkey sTNF-R I concentration.
- **For samples which have been diluted according to the instructions given in this manual 1:10 within the microwells, the concentration read from the standard curve must be multiplied by the dilution factor (x 10).**

Note: Calculation of samples with an O.D. exceeding 2.0 may result in incorrect, low monkey sTNF-R I levels. Such samples require further dilution of 1:20 - 1:40 with Assay Buffer in order to precisely quantitate the actual monkey sTNF-R I level.
- It is suggested that each testing facility establishes a control sample of known monkey sTNF-R I concentration and runs this additional control with each assay. If the values obtained are not within the expected range of this control, the assay results may be invalid.
- A representative standard curve is shown in Figure 3. This curve cannot be used to derive test results. Every laboratory must prepare a standard curve for each group of microwell strips assayed.

Figure 3. Representative standard curve for monkey sTNF-R I ELISA. Monkey sTNF-R I was diluted in serial two-fold steps in Assay Buffer, symbols represent the mean of three parallel titrations.

Do not use this standard curve to derive test results. A standard curve must be run for each group of microwell strips assayed.

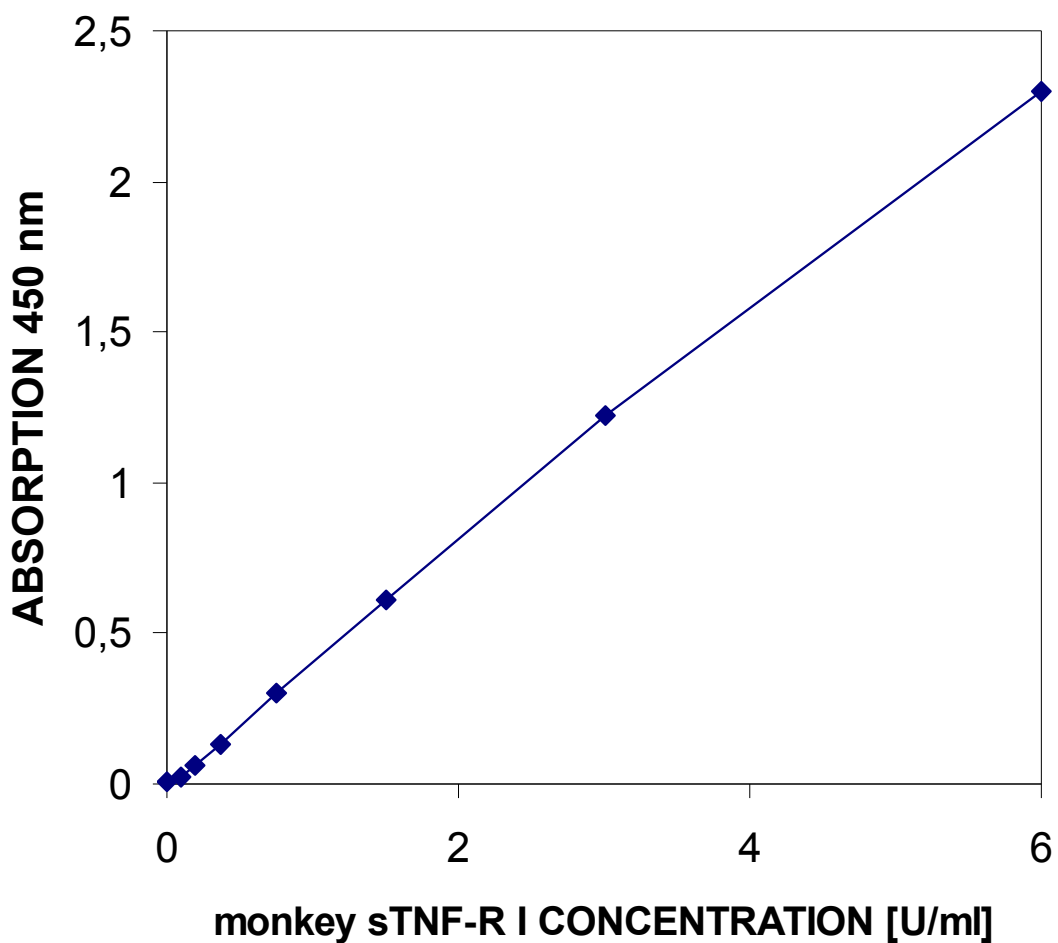

Typical data using the monkey sTNF-R I ELISA

Measuring wavelength: 450 nm

Reference wavelength: 620 nm

Standard	monkey sTNF-R I Concentration (U/ml)	O.D. Mean	C.V. (%)
1	6	2.300	1.3
	6		
2	3	1.221	0.8
	3		
3	1.5	0.610	1.3
	1.5		
4	0.75	0.305	1.8
	0.75		
5	0.375	0.135	2.4
	0.375		
6	0.19	0.061	1.6
	0.19		
7	0.09	0.025	0.8
	0.09		
Blank	0	0.010	
	0		

12 LIMITATIONS

- Since exact conditions may vary from assay to assay, a standard curve must be established for every run.
- Bacterial or fungal contamination of either screen samples or reagents or cross-contamination between reagents may cause erroneous results.
- Disposable pipette tips, flasks or glassware are preferred, reusable glassware must be washed and thoroughly rinsed of all detergents before use.
- Improper or insufficient washing at any stage of the procedure will result in either false positive or false negative results. Completely empty wells before dispensing fresh Wash Buffer, fill with Wash Buffer as indicated for each wash cycle and do not allow wells to sit uncovered or dry for extended periods.

13 PERFORMANCE CHARACTERISTICS

A. Sensitivity

The limit of detection of monkey sTNF-R I defined as the analyte concentration resulting in an absorption significantly higher than that of the dilution medium (mean plus two standard deviations) was determined to be less than 0.059 U/ml (mean of 6 independent assays).

B. Reproducibility

a. Intra-assay

Reproducibility within the assay was evaluated in independent experiments. The overall Intra-assay coefficient of variation has been calculated to be 2%.

b. Inter-assay

Assay to assay reproducibility within one laboratory was evaluated in independent experiments by three technicians. The overall inter-assay coefficient of variation has been calculated to be 9%.

C. Spiking Recovery

The spiking recovery was evaluated by spiking two levels of monkey sTNF-R I into pooled monkey serum diluted 1:10. The overall mean recovery was 93%.

D. Dilution Linearity

Three serum samples with different levels of monkey sTNF-R I were assayed at four serial two-fold dilutions (1:5 - 1:40) with 4 replicates each. The overall mean recovery was 105%.

E. Sample Stability

a. Freeze-Thaw Stability

Aliquots of serum samples (unspiked or spiked) were stored at -70°C and thawed up to 5 times, and monkey sTNF-R I levels determined. There was no significant loss of monkey sTNF-R I by freezing and thawing.

b. Storage Stability

Aliquots of a serum sample (spiked or unspiked) were stored at -20°C , $2-8^{\circ}\text{C}$, room temperature (RT) and at 37°C , and the monkey sTNF-R I level determined after 24 h. There was no significant loss of monkey sTNF-R I immunoreactivity during storage under above conditions.

14 REFERENCES

- 1) Aggarwal, B.B., T.E. Eessalu, and P.E. Hass. (1985). Characterization of receptors for human tumour necrosis factor and their regulation by gamma-interferon. *Nature* 318, 665 - 667.
- 2) Aggarwal, B.B. (1987). Tumor necrosis Factor - TNF- α and TNF- β : their structure pleiotropic biological effects. *Drugs Future* 12, 891 - 898.
- 3) Baglioni, C., S. McCandless, J. Tavernier, and W. Fiers (1985). Binding of human tumor necrosis factor to high affinity receptors on HeLa and lymphoblastoid cells sensitive to growth inhibition. *J. Biol. Chem.* 260, 13395 - 13397.
- 4) Beutler, B., J. Mahoney, N. Le Trang, P. Pekala, and A. Cerami. (1985). Purification of cachectin, a lipoprotein lipase-suppressing hormone secreted by endotoxin-induced RAW 264.7 cells. *J. Exp. Med.* 161, 984 - 995.
- 5) Beutler, B., and A. Cerami. (1987). Cachectin: more than a tumor necrosis factor. *N. Eng. J. Med.* 316, 379 - 385.
- 6) Brockhaus, M., H.J. Schoenfeld, E.J. Schlaeger, W. Hunziker, W. Lesslauer, and H. Loetscher. (1990). Identification of two types of tumor necrosis factor receptors on human cell lines by monoclonal antibodies. *Proc. Natl. Acad. Sci. USA* 87, 3127 - 3131.
- 7) Carswell, E.A., L.J. Old, R.L. Kassel, S. Green, N. Fiore, and B. Williamson. (1975). An endotoxin-induced serum factor that causes necrosis of tumors. *Proc. Natl. Acad. Sci. USA* 72, 3666 - 3670.
- 8) Creasey, A.A., R. Yamamoto, and C.R. Vitt. (1987). A high molecular weight component of the human tumor necrosis factor receptor is associated with cytotoxicity. *Proc. Natl. Acad. Sci. USA* 84, 3293 - 3297.

- 9) Kull, F.C., S. Jacobs, and P. Cuatrecasas. (1985). Cellular receptor for ^{125}I -labeled tumor necrosis factor: specific binding, affinity labeling, and relationship to sensitivity. Proc. Natl. Acad. Sci. USA 82, 5756 - 5760.
- 10) Munker, R., J. DiPersio, and H.P. Koeffler. (1987). Tumor Necrosis Factor: Receptors on Hematopoietic Cells. Blood 70, 1730 - 1734.
- 11) Old L. (1985). Tumor necrosis factor (TNF). Science 230, 630 -
- 12) Paul N., and N. Ruddle. (1988). Lymphotoxin. Ann. Rev. Immunol. 6, 407 - 438.
- 13) Rubin B., S. Anderson, S. Sullivan, B. Williamson, E. Carswell, and L. Old. (1985). High affinity binding of ^{125}I -labeled human tumor necrosis factor (LuKII) to specific cell surface receptors. J. Exp. Med. 162, 1099 - 1104.
- 14) Scheurich, P., U. Ücer, M. Krönke, and K. Pfizenmaier. (1986). Quantification and characterization of high-affinity membrane receptors for tumor necrosis factor on human leukemic cell lines. Int. J. Cancer 38, 127 - 133.
- 15) Scheurich, P., B. Thoma, U. Ücer, and K. Pfizenmaier. (1987). Immunoregulatory activity of recombinant human tumor necrosis factor (TNF)- α : Induction of TNF receptors on human T cells and TNF- α mediated enhancement of T cell responses. J. Immunol. 138, 1786 - 1790.
- 16) Thoma, B., M. Grell, K. Pfizenmaier, and P. Scheurich. (1990). Identification of a 60-kD tumor necrosis factor (TNF) receptor as the major signal transducing component in TNF responses. J. Exp. Med. 172, 1019 - 1023.
- 17) Tsujimoto, M., Y.K. Yip, and J. Vilcek. (1985). Tumor necrosis factor: Specific binding and internalization in sensitive and resistant cells. Proc. Natl. Acad. Sci. USA 82, 7626 - 7630.

15 REAGENT PREPARATION SUMMARY

A. Wash Buffer Add **Wash Buffer Concentrate** 20 x (50 ml) to 950 ml distilled water

B. Assay Buffer	Number of Strips	Assay Buffer Concentr. (ml)	Distilled Water (ml)
	1 - 6	2.5	47.5
	1 - 12	5.0	95.0

C. HRP-Conjugate	Number of Strips	HRP-Conjugate (ml)	Assay Buffer (ml)
	1 - 6	0.03	2.97
	1 - 12	0.06	5.94

D. Standard Add **Assay Buffer** as stated on the label of the standard vial to each vial of concentrated **monkey sTNF-R I Standard** as needed.

16 TEST PROTOCOL SUMMARY

- Wash microwell strips twice with **Wash Buffer**
- Add 100 µl **Assay Buffer**, in duplicate, to standard wells.
- Pipette 100 µl diluted **monkey sTNF-R I Standard** into the first wells and create standard dilutions ranging from 6 to 0.09 U/ml by transferring 100 µl from well to well. Discard 100 µl from the last wells
- Add 100 µl **Assay Buffer**, in duplicate, to the blank wells
- Add 90 µl **Assay Buffer** to the sample wells
- Add 10 µl **Sample**, in duplicate, to designated wells
- Prepare **HRP-Conjugate**
- Add 50 µl of diluted **HRP-Conjugate** to all wells
- Cover microwell strips and incubate 2 hours at room temperature (18° to 25°C)
- Empty and wash microwell strips 3 times with **Wash Buffer**
- Add 100 µl of **TMB Substrate Solution** to all wells including blank wells
- Incubate the microwell strips for about 15 minutes at room temperature (18°to 25°C).
- Add 100 µl **Stop Solution** to all wells including blank wells
- Blank microwell reader and measure colour intensity at 450 nm

Note: For samples which have been diluted according to the instructions given in this manual 1:10, the concentration read from the standard curve must be multiplied by the dilution factor (x 10). Calculation of samples with an O.D. exceeding 2.0 may result in incorrect, low monkey sTNF-R I levels. Such samples require further dilution of 1:20 - 1:40 with Assay Buffer in order to precisely quantitate the actual monkey sTNF-R I

NOTES



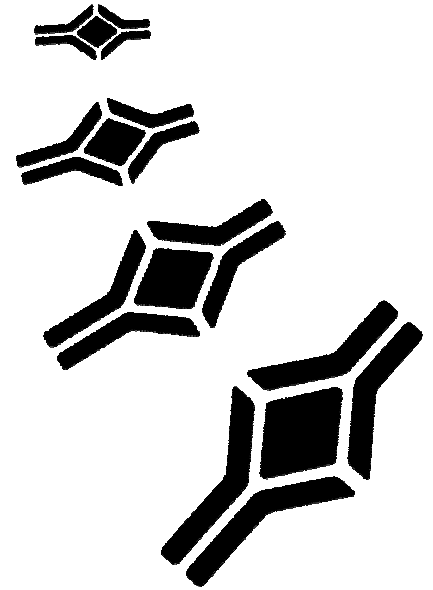

HEADQUARTERS:

BioVendor Laboratorní
medicína, a.s.

CTPark Modrice
Evropska 873

664 42 Modrice
CZECH REPUBLIC

Phone: +420-549-124-185
Fax: +420-549-211-460

E-mail: info@biovendor.com
Web: www.biovendor.com

EUROPEAN UNION:
BioVendor GmbH

Im Neuenheimer Feld 583

D-69120 Heidelberg
GERMANY

Phone: +49-6221-433-9100
Fax: +49-6221-433-9111

E-mail: infoEU@biovendor.com

USA, CANADA AND MEXICO:
BioVendor LLC

1463 Sand Hill Road
Suite 227

Candler, NC 28715
USA

Phone: +1-828-670-7807
+1-800-404-7807
Fax: +1-828-670-7809

E-mail: infoUSA@biovendor.com

CHINA - Hong Kong Office:
BioVendor Laboratories Ltd

Room 4008
Hong Kong Plaza, No.188

Connaught Road West
Hong Kong, CHINA

Phone: +852-2803-0523
Fax: +852-2803-0525

E-mail: infoHK@biovendor.com

CHINA – Mainland Office:
BioVendor Laboratories Ltd

Room 2405 YiYa Tower
TianYu Garden, No.150

Lihe Zhong Road
Guang Zhou, CHINA

Phone: +86-20-8706-3029
Fax: +86-20-8706-3016

E-mail: infoCN@biovendor.com